



***Impact Study  
For  
Generation Interconnection  
Request  
GEN-2005-012***

***SPP Tariff Studies***

***(#GEN-2005-012)***

***July 2006***

## **Executive Summary**

<OMITTED TEXT> (Customer) has requested an Impact Study under the Southwest Power Pool Open Access Transmission Tariff (OATT) for interconnection of a 403 MW wind powered generation facility in Ford County, Kansas to the transmission system of Sunflower Electric Cooperative. The wind powered generation facility was studied with two-hundred-twenty-four (224) individual Vestes V80 1.8MW wind turbines. The requested in-service date for the 403MW facility is December 31, 2008. This Impact study addresses the dynamic stability effects of interconnecting the plant to the rest of the SPP transmission system as well as addressing the need for reactive compensation required by the wind farm because of the use of the Vestes turbines.

The generation facility will interconnect into the Spearville 345kV substation in Ford County. This interconnection facility is estimated to cost \$905,000. From Spearville substation, the Customer will build a 345kV line to its 345/34.5kV collector substation. This substation will have feeder connections to the wind turbine collection circuits.

Two seasonal base cases were used in the study to analyze the stability impacts of the proposed generation facility. The cases studied were the 2007 winter peak, and the 2011 summer peak case. Each case was modified to include prior queued projects that are discussed in the body of the report. The Vestes V80 1.8MW wind turbines were modeled using information provided by the manufacturer. Fourteen contingencies were simulated.

Stability Analysis of the request using the latest dynamic model from PTI indicate that due to conditions in the power system for the outage of the Holcomb-Spearville 345kV that the wind farm shall be limited to and interconnected at 300MW output as long as the required capacitors and dynamic reactive sources are installed. At 300MW output, the Customer shall be required to install 24MVAR of capacitor banks on each of the 34.5kV substation buses in the Customer substation, for a total of 48 MVAR. At 300MW output, the Customer shall also be required to install a 34.5kV, +/- 20MVAR STATCOM device on each of the 34.5kV busses, for a total of two. These provisions are made on the assumption that all previous queued projects are operating with no new transmission improvements. If transmission improvements are made in the area, a smaller size STATCOM may be required.

Stability Analysis shows that at 300MW, with the required capacitor banks and STATCOM devices, the transmission system will remain stable for all simulated contingencies studied.

Further Stability study results show that in with all previously mentioned conditions the wind farm will meet the 'Transitional' provisions of FERC Order #661A's Low Voltage Ride Through (LVRT) provisions.

The Customer has the option of requesting a restudy when Power Technologies Inc. (PTI) has completed the redesign of the dynamic model for the Vestes wind turbine. Communication with PTI indicated the new model would not be completed in time for the completion of this study.

Nothing in this study should be construed as a guarantee of transmission service. If the customer wishes to sell power from the facility, a separate request for transmission service shall be requested on Southwest Power Pool's OASIS by the Customer.

## **1.0 Introduction**

<OMITTED TEXT> (Customer) has requested an Impact Study under the Southwest Power Pool Open Access Transmission Tariff (OATT) for interconnecting up to a 400 MW wind powered generation facility in Ford County, Kansas to the transmission system of Sunflower Electric Cooperative. The wind powered generation facility studied was proposed to comprise of two-hundred-twenty-four (224) individual 1.8MW Vestes V80 wind turbines. This study has determined the maximum amount of generation that can be interconnected without transmission improvements is 300MW. These 300MW will consist of one-hundred-sixty-eight (168) Vestes V80 turbines. The requested in-service date for the facility is December 1, 2008. The wind powered generation facility will interconnect into the 345kV bus at Spearville substation. The 345kV bus is owned by Sunflower. This study will address the stability and reactive compensation issues associated with the Vestes turbines.

## **2.0 Purpose**

The purpose of the Interconnection System Impact Study is to evaluate the impact of the proposed interconnection on the reliability of the Transmission System. The Impact Study considers the Base Case as well as all Generating Facilities (and with respect to (iii) below, any identified Network Upgrades associated with such higher queued interconnection) that, on the date the Interconnection System Impact Study is commenced: (i) are directly interconnected to the Transmission System; (ii) are interconnected to Affected Systems and may have an impact on the Interconnection Request; (iii) have a pending higher queued Interconnection Request to interconnect to the Transmission System; and (iv) have no Queue Position but have executed an LGIA or requested that an unexecuted LGIA be filed with FERC.

There are several previously queued projects in the immediate area ahead of this request in the SPP Generation Interconnection queue. It was assumed for purposes of this study that those projects would be in-service if this project is built. Any changes to this assumption, i.e. one or more of the previously queued projects not included in the study signing an interconnection agreement, may require a re-study of this request at the expense of the customer. Other wind farms which have higher queue priority than this request were modeled in this case.

Nothing in this System Impact Study constitutes a request for transmission service or confers upon the Interconnection Customer any right to receive transmission service.

## **3.0 Facilities**

### **3.1 Generating Facility**

The generating facility was studied with the assumption that it would be using the Vestes V80 1.8MW wind turbines. The nameplate rating of each turbine is 1.8MW (1800kW) with a machine base of 2000kVA. The turbine output voltage is 690V.

Vestes has provided optional equipment configurations that consist of enhanced low voltage ride through capability and improved power electronics that will improve efficiency and grid response to power fluctuations. This package is known as the AGO-4 package and will be required for this request because of the low voltage ride through requirements of FERC Order #661A. This study was conducted using the latest Vestes Voltage and Frequency Settings with Fault Ride Through modeling stability package available from PTI

### **3.2 Interconnection Facility**

The Customer has proposed an interconnection facility, which would connect to the Sunflower transmission system via a new position in the 345kV bus at the Spearville substation in Ford County, Kansas. The new terminal at Spearville will house a new line to the new Customer 345/34.5kV transformation substation including two transformers that serve the wind powered generation facility.

Analysis of the reactive compensation requirements of the wind farm determined the need for two sets of 34.5kV staged capacitor banks, sized at 24MVAR each. Each bank will be located on the secondary side of each substation transformer. This bank is necessary for reactive compensation for the wind farm (turbine and collector system losses).

Due to conditions under contingency (outage of the Spearville-Holcomb 345kV line), a total of two (2) 34.5kV +/- 20MVAR STATCOM devices are required on each 34.5kV substation bus for the Vestes wind turbines to remain stable under this contingency.

The total cost for adding the new 345kV terminal to Spearville substation, the required interconnection facility is estimated at \$900,000. This cost does not include the Customer 345/34.5kV substation, the 34.5kV capacitor banks, the 34.5kV STATCOM devices, or the 345kV line connecting the Customer substation to Spearville substation. The one-line diagram for this configuration is shown in Figure 1.

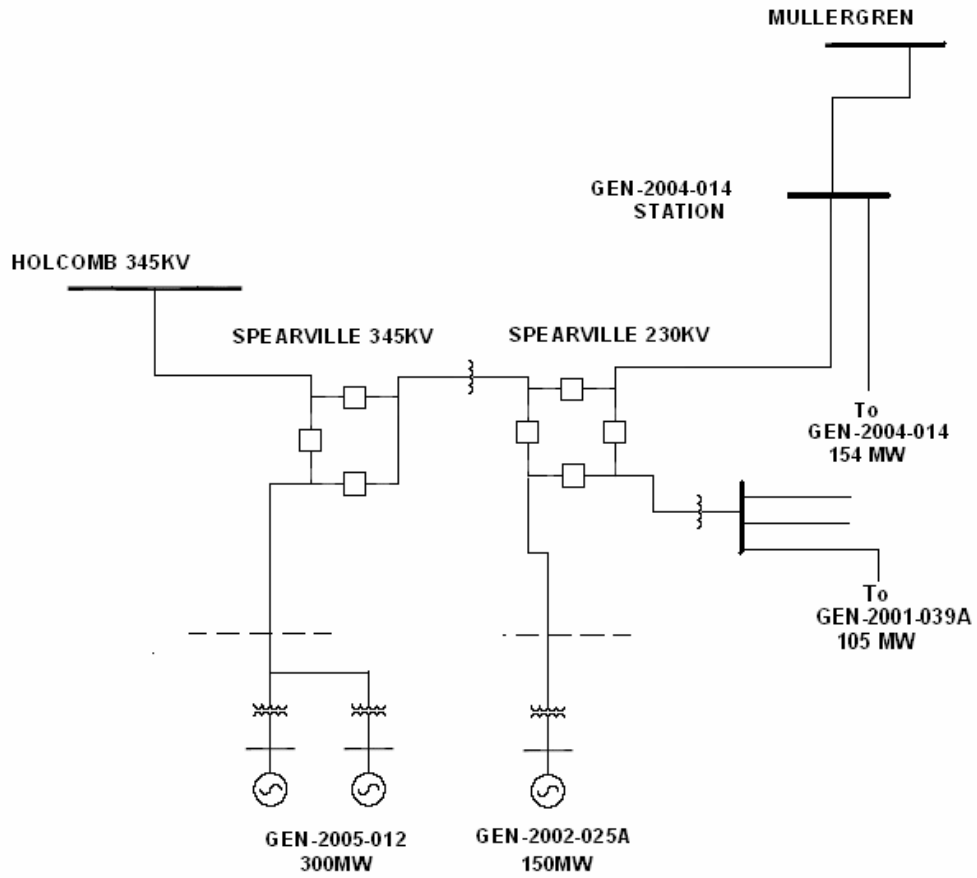

**Figure 1: Proposed Interconnection Configuration  
(Final substation design to be determined)**

## **4.0 Stability Analysis**

### **4.1 Objective**

The objective of the stability study is to determine the impact on system stability of connecting the proposed GEN-2005-012 wind farm to SPP's 345 kV transmission system.

### **4.2 Equivalent Modeling of the Wind Generating Facility**

The rated output of the modified generation facility is 300MW, comprised of 168 Vestes V80 1.8MW wind turbines. The base voltage of the Vestes turbine is 690 V, and a generator step up transformer (GSU) of 1.85MVA connects each unit to the high side of 34.5kV. The rated power output of each turbine is 1.8MW while the actual power output depends on the wind.

In performing a system impact study, the wind farm generation from the study customer and previously queued customers is dispatched into the SPP footprint.

The generating facility 345/34.5 substation will consist of (2) 345/34.5kV transformers with an impedance of 10% on a 93 MVA OA Base with a top rating of 155MVA. From the one-lines received from the customer, on the 34.5kV side of the transformer, 16 feeder circuits each will extend from the Customer's 345/34.5kV substation. The feeders will consist of 14 wind turbines respectively on each circuit as shown in Figure 2. This study determined that the maximum number of feeders this interconnection configuration could support is twelve feeders for a total of 168 turbines.

### **4.3 Modeling of the Wind Turbines in the Power Flow**

In order to simplify the model of the wind farm while capturing the effect of the different impedances of cables (due to change of the conductor size and length), the wind turbines connected to the same 34.5kV feeder end points were aggregated into one equivalent unit. An equivalent impedance of that feeder is represented in the load flow database by taking the equivalent series impedances of the different feeders connecting the wind turbines. Using this approach, the wind farm was modeled with equivalent units.

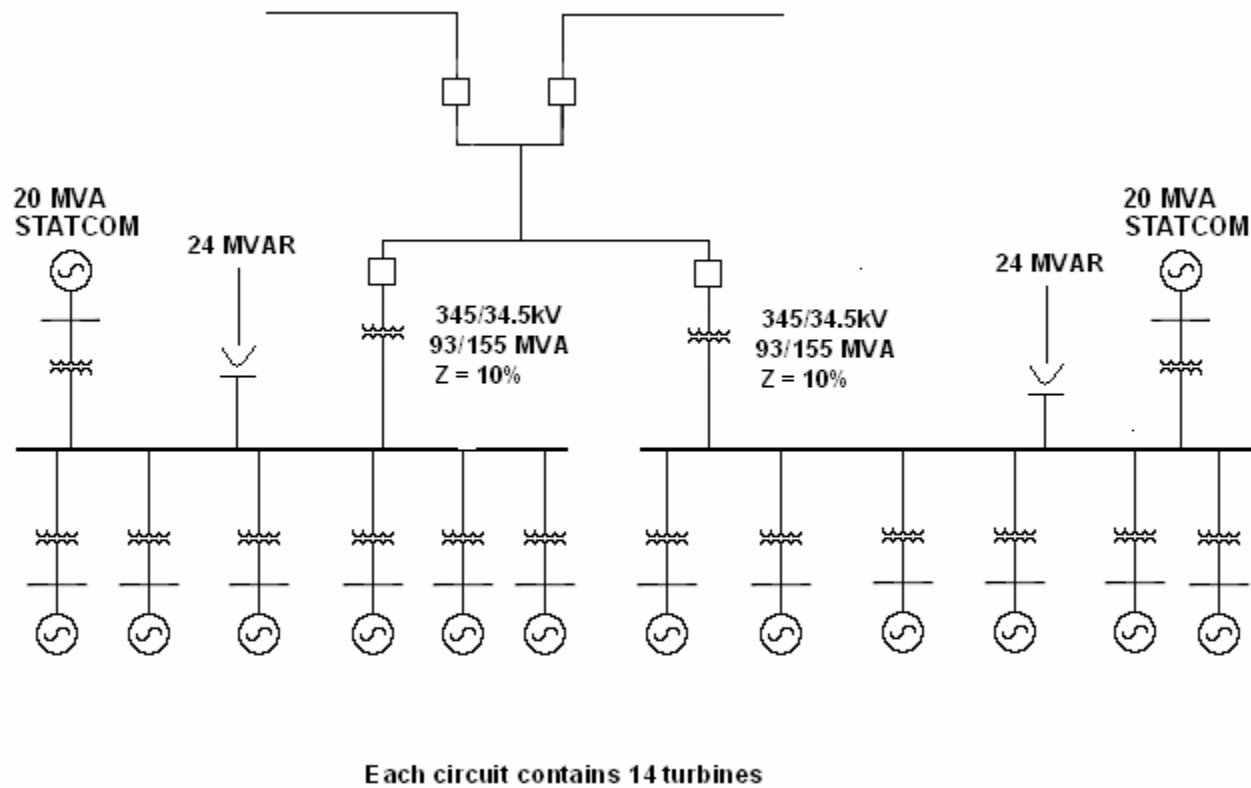

**Figure 2. One-Line Drawing of the GEN-2005-012 Facility**

## **4.4 Modeling of the Wind Turbines for the Stability Simulation**

### **4.4.1 Machine Dynamics Data**

The customer requested that the System Impact Study for the project to include Vestas V80-1.8 MW wind turbines. The Vestas V80-1.8 MW turbines are a three phase induction generators with a proprietary rotor resistance control called “optislip control”. The following are the main electrical parameters of the Vestas V80-1.8 MW wind turbine.

Rated Power : 1.8 MW  
Voltage : 690 V  
Power Factor Correction : 864 kVAR

Table 1. shows the model parameters of an equivalent generator at the collector bus.

<b>Parameter</b>	<b>Value</b>
BASE KV	0.690
WTG MBASE	2.0
TRANSFORMER MBASE	1.85
TRANSFORMER R ON TRANSFORMER BASE	0.0000
TRANSFORMER X ON TRANSFORMER BASE	0.075
GTAP	1.0
PMAX	1.8
PMIN	0.0
RA	0.0048897
LA	0.12602
LM	6.8399
R_ROT_MACH	0.004419
L1	0.18084
INERTIA	0.644
DAMPING	0.0

**Table 1. Vestas 1.8 MW Wind Generator Data**

The manufacturer’s Advanced Grid Option 4 (AGO4) voltage and frequency protection were used. The voltage and frequency protection settings provided by the manufacturer are as follows:



<b>Protective Function</b>	<b>Protection Setting</b>	<b>Time Delay</b>
Over Frequency	61.5 Hz	90 seconds
Under Frequency	57.0 Hz	2.0 seconds
Under Voltage	50%	0.2 seconds
Under Voltage	75%	0.80 seconds
Under Voltage	80%	2.0 seconds
Under Voltage	90%	300.0 seconds
Over Voltage	115%	30.0 seconds
Over Voltage	120%	2.0 seconds
Over Voltage	125%	0.08 seconds

**Table 2. Vestes Turbine Voltage & Frequency Protection**

Power Technologies Inc. (PTI) has produced a Vestes V80 turbine model package for use on their PSS/E simulation software. This package was obtained from PTI and was used exclusively in modeling this wind farm. The Vestes stability model package used was released by Siemens PTI in July, 2005.

PTI is in the process of updating the software due to known limitations of the model that occur during certain system conditions. However, PTI indicated the new model would not be available in time for this study.

FERC Order #661A places specific requirements on wind farms through its Low Voltage Ride Through (LVRT) provisions. For Interconnection Agreements signed before December 31, 2006, wind farms shall stay on line for faults at the point of interconnection (POI) that draw the voltage down to 0.15 pu at the POI (Spearville 345kV bus). For Agreements signed after December 31, 2006, wind farms shall stay on line for faults at the POI that draws the voltage down at the POI to 0.0 pu.

Using the AGO-4 LVRT package and the required STATCOM devices, this wind farm is compliant with FERC Order #661A.

#### **4.5 Contingencies Simulated**

Fourteen (14) contingencies were considered for the transient stability simulations which included three phase faults, as well as single phase line faults, at the locations defined by SPP. Single-phase line faults were simulated by applying a fault impedance to the positive sequence network at the fault location to represent the effect of the negative and zero sequence networks on the positive sequence network. The fault impedance was computed to give a positive sequence voltage at the specified fault location of approximately 60% of pre-fault voltage. This method is in agreement with SPP current practice.

The faults that were defined and simulated are listed in Table 3.

**Table 3. Contingencies Evaluated**

<i>Cont. No.</i>	<i>Cont. Name</i>	<i>Description</i>
1	FLT13PH	3 phase fault on the Spearville (56469) to Holcomb (56449) 345 kV line, near Spearville. a. Apply fault at the Spearville bus (56469). b. Clear fault after 5 cycles by tripping the line from Spearville (56469) to Holcomb (56449). c. Wait 20 cycles, and then re-close the line in (b) back into the fault. d. Leave fault on for 5 cycles, then trip the line in (b) and remove fault.
2	FLT21PH	<i>Single phase fault and sequence like Cont. No. 1</i>
3	FLT33PH	3 phase fault on the Holcomb (56449) to Finney (50858) 345 kV line, near Holcomb. a. Apply fault at the Holcomb bus. b. Clear fault after 5 cycles by tripping the line from Finney to Holcomb.
4	FLT43PH	3 phase fault on the Spearville 345kV bus a. Apply fault at the Spearville bus. b. Clear fault after 5 cycles by tripping the Spearville 345/230kV autotransformer from service.
5	F05-3PH	3-phase fault at Mullergren on 230 kV line to Spearville <u>Time</u> <u>Fault Clearing</u> 5            Trip breaker at Mullergren for line 58779[MULGREN6] - 58795[SPEARVL6] 7            Clear fault
6	F05-SLG	SLG fault at Mullergren on 230 kV line to Spearville, Breaker failure at Mullergren, [CB6012] <u>Time</u> <u>Fault Clearing</u> 7            Trip breaker at Spearville for line [MULGREN6] - 58795[SPEARVL6] 16          Trip line 58779[MULGREN6]-56871[CIRCLE6] Clear fault
7	F06-3PH	3-phase fault at Spearville on 230 kV line to Mullergren <u>Time</u> <u>Fault Clearing</u> 5            Trip breaker at Spearville for line 58779[MULGREN6] -[SPEARVL6] 7            Clear fault
8	F06-SLG	SLG fault at Spearville on 230 kV line to Mullergren, Breaker failure at Mullergren, [CB6012] <u>Time</u> <u>Fault Clearing</u> 5            Trip breaker at Spearville for line 58795[SPEARVL6]-[MULGREN6] 16          Trip line 58779[MULGREN6]-56871[CIRCLE6] Clear fault
9	F07-3PH	3-phase fault at North Judson Large on 115 kV line to Spearville <u>Time</u> <u>Fault Clearing</u> 7            Trip breaker at North Judson Large for line 58871[NOR-JUD3] - SVL3] 9            Clear fault

<i>Cont. No.</i>	<i>Cont. Name</i>	<i>Description</i>
10	F07-SLG	<p>SLG fault at North Judson Large on 115 kV line to Spearville Breaker failure at North Judson Large, [CB3071]</p> <p><u>Time</u>    <u>Fault Clearing</u>  9        Trip breaker at Spearville for line 58871[NOR-JUD3] -----  -----58794[SPEARVL3]  20        Trip line 58871[NOR-JUD3] -58771[JUD-LRG3]  Trip line 58767[HAGGARD3]-58799[W-DODGE3]  Clear fault</p>
11	F08-3PH	<p>3-phase fault at Judson Large on 115 kV line to Clipper Tap</p> <p><u>Time</u>    <u>Fault Clearing</u>  7        Trip breaker at Judson Large for line 58771[JUD-LRG3] -----  -----59350[CLIPTAP]  9        Clear fault</p>
12	F08-SLG	<p>SLG fault at Judson Large on 115 kV line to Clipper Tap Breaker failure at Judson Large, [CB3629]</p> <p><u>Time</u>    <u>Fault Clearing</u>  9        Trip breaker at Spearville for 58771[JUD-LRG3] -59350[CLIPTAP]  20        Trip line 58771[JUD-LRG3] -58871[NOR-JUD3]  Trip line 58771[JUD-LRG3] -58840[EDODGE3]  Trip line 58754[CIM-PLT3] - 58752[CMRIVTP3]  Trip line 58772[E-LIBER3] -58752[CMRIVTP3]  30        Trip generator at 58770[JUD-LRG1]  Clear fault</p>
13	F09-3PH	<p>3-phase fault at Clipper Tap on 115 kV line to Greensburg</p> <p><u>Time</u>    <u>Fault Clearing</u>  7        Trip breaker at Clipper Tap for line 59350[CLIPTAP] -  58764[GRNBURG3]  9        Clear fault</p>
14	F09-SLG	<p>SLG fault at Clipper Tap on 115 kV line to Greensburg Breaker failure at Medicine Lodge, [CB3102]</p> <p><u>Time</u>    <u>Fault Clearing</u>  7        Trip breaker at Clipper Tap for line 59350[CLIPTAP] -  58764[GRNBURG3]  20        Trip line 58773[MED-LDG3] -58797[SUNCITY3]  Clear fault</p>

#### **4.6 Further Model Preparation**

The contingencies were simulated for the following scenarios

- 2011 Summer Peak Loading
- 2007 Winter Peak Loading

The previously queued projects which were added to the stability base case are summarized in Table 4.

Study Plant	Total MW
Aquila PQ1 (in service)	110
Aquila PQ2 (GEN-2001-039A)	105
Aquila PQ3 (GEN-2002-25A)	150
GEN-2004-014	154

**Table 4 – Summary of Prior Queued Projects**

#### **4.7 Results**

Results are summarized in Table 5.

Under the worst case condition, the outage of the Spearville-Holcomb 345kV line, transmission capacity is limited to the rating of the Spearville 345/230kV autotransformer, which is 336MVA. With all previous queued projects running and with no transmission improvements modeled, the transmission voltage in the area deteriorates under this contingency to a point that the Vestes turbines will not operate properly. The power output as well as the voltage of the turbine is observed to 'scribble' as shown below in Figure 3. Consultation with PTI, the software designer of the dynamic model for Vestes, has indicated that while the simulated conditions may not actually occur, it does indicate a condition in the transmission system in the area of the interconnection that may not allow the Vestes turbines to operate in a stable manner. Recommendations for PTI for this condition were two-fold. The first recommendation is to reduce the power output of the wind farm. The second is to add dynamic reactive compensation.

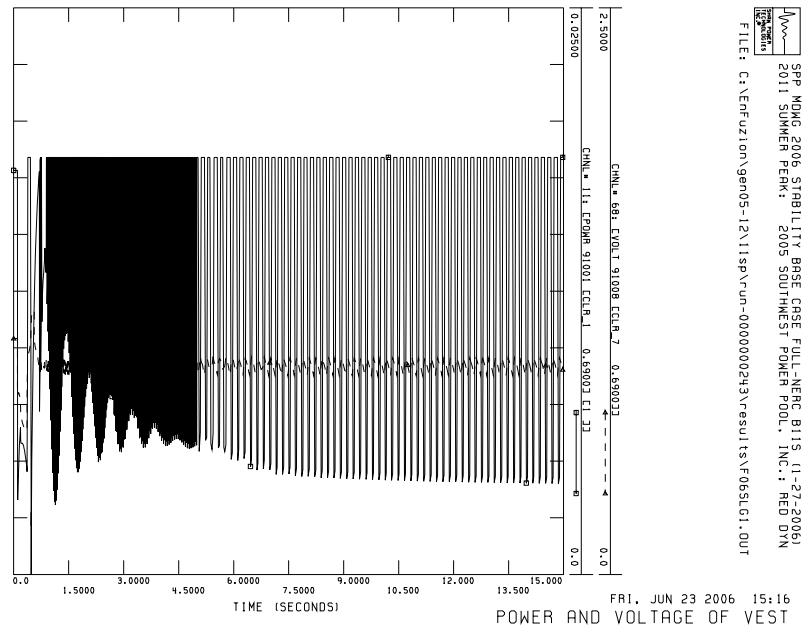

**Figure 3. Scribble of Vestes Turbines**

Acting upon the recommendations of PTI, SPP attempted to size a STATCOM device that would allow the Vestes turbines to operate in a stable manner for the Holcomb-Spearville 345kV outage while maintaining a wind farm output of 400MW. SPP tested STATCOM devices and found that two 40MVA STATCOM devices along with 72MVAR of capacitors were needed for the Vestes turbines to operate in a stable manner. Figure 4. shows the power output of the wind farm and Vestes turbines at 400MW output with a 30MVA STATCOM device.

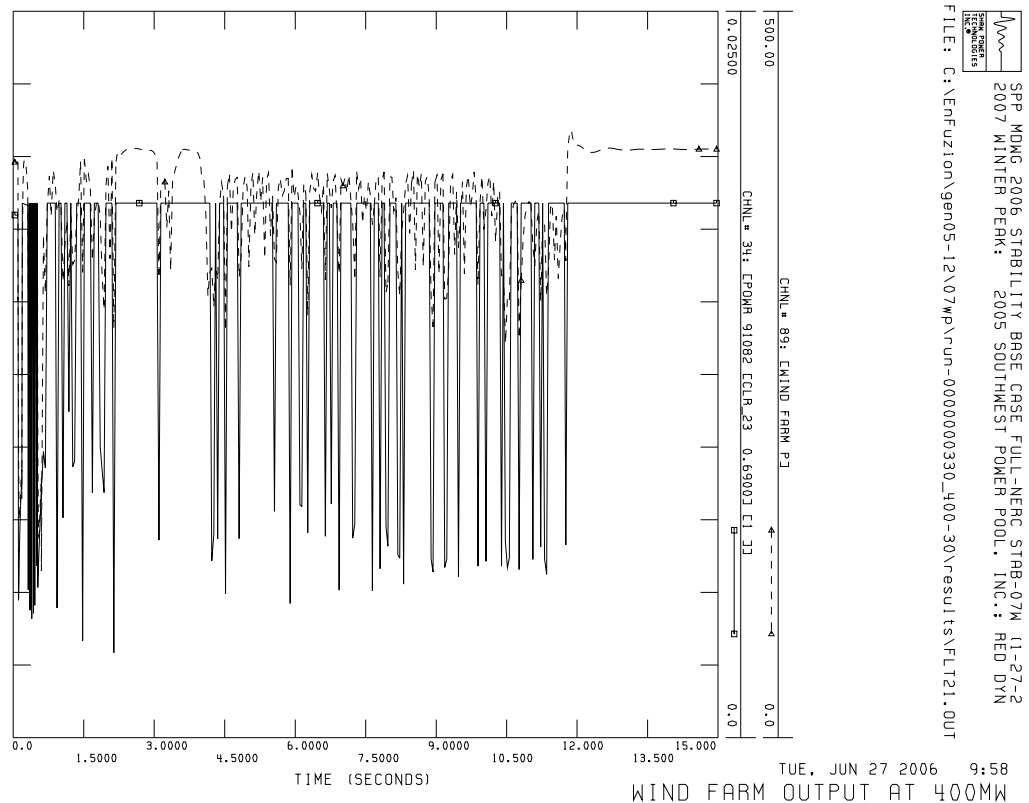

**Figure 4. Wind Farm Power Output at 400MW**

The limiting factor of the interconnection is the Spearville 345/230kV autotransformer which has a rating of 336MVA. Therefore, the decision was made by SPP not to size the STATCOM device for a plant output that could not be accommodated without transmission reinforcements. Once transmission reinforcements are built, a smaller size STATCOM may be able to accommodate the plant. In order to reduce the wind farm output below 336 MVA and to keep the loading on each of the two substation transformers equal, two collector circuits were removed from each transformer for a total of 302.4 MW of wind turbines for the wind farm.

For the output of 300MW, a total of two (2) 34.5kV, 20MVA STATCOM devices are required with 48MVAR of capacitors in order for the Vestes turbines to operate in a stable manner. The power output for the wind farm for all contingencies for the 2007wp is shown in Figure 5.

The transmission system was found to remain stable for all contingencies tested with the wind farm output at 300MW and the required capacitors and STATCOM devices.

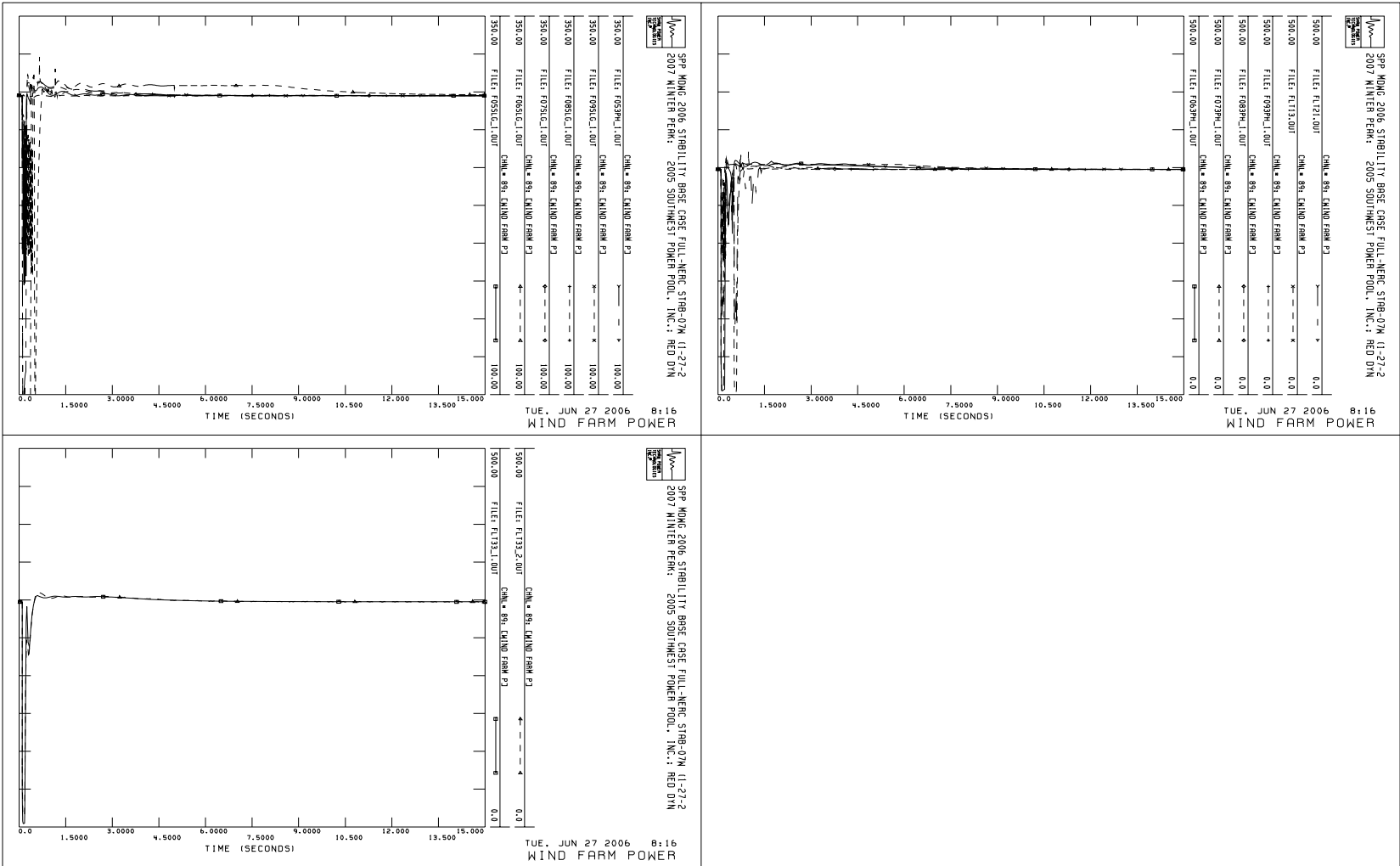

Figure 5. Wind Farm Power Output for 2007 wp for all contingencies for 300MW and STATCOM devices

PTI has communicated with SPP that it intends to update the Vestes V80 dynamic model in the future. However, at the time of this study, it was apparent the model was not going to be complete in time for this study. At the Customer's request, SPP may be able to conduct a selective restudy during the Facility Study to determine if a smaller STATCOM device may be required due to improvements in the PTI model for the Vestes turbines.

FERC Order #661A Compliance – Contingency FLT13PH and FLT33PH were simulated explicitly for determining compliance with FERC Order #661A. This request will fall under the 'Transitional' clause of the Order's Low Voltage Ride Through (LVRT) provisions if an Interconnection Agreement is signed before December 31, 2006. The 'Transitional' clause states that the turbines should stay on line for a 5-9 cycle fault that produces 0.15 pu voltage at the point of interconnection. For this study, the fault duration was treated the same as the other faults simulated (5 cycles).

The wind farm was modeled using the Vestes AGO-4 low voltage ride through package. By installing the AGO-4 package and the necessary capacitors and STATCOM devices, this wind farm will meet Order #661A low voltage ride through requirements.



<b>FAULT</b>	<b>FAULT DEFINITION</b>	<b>2011 SP</b>	<b>2007 WP</b>
FLT13PH	Three phase fault on the Spearville-Holcomb 345kV line at Spearville.	STABLE -PQ1-	STABLE -PQ1-
FLT21PH	Single phase fault same as above	STABLE	STABLE
FLT33PH	Three phase fault on the Holcomb-Finney 345kV near Holcomb.	STABLE	STABLE
FLT43PH	Three phase fault on the Spearville 345/230kV autotransformer	STABLE -PQ1-	STABLE -PQ1-
F05SLG	Single phase fault on the Spearville-Mullergren 230kV, near Spearville breaker failure at Mullergren	STABLE	STABLE
F053PH	Three phase fault on the Spearville-Mullergren 230kV near Spearville	STABLE	STABLE
F06SLG	Single phase fault on the Spearville-Mullergren 230kV line, near Mullergren breaker failure at Mullergren	STABLE	STABLE
F063PH	Three phase fault on the Spearville-Mullergren 230kV line, near Mullergren	STABLE	STABLE
F07SLG	Single phase fault on the North Judson Large-Spearville 115kV line, near North Judson Large, breaker failure at North Judson Large	STABLE	STABLE
F073PH	Three phase fault on the North Judson Large-Spearville 115kV line, near North Judson Large	STABLE	STABLE
F08SLG	Single phase fault on the Judson Large-Medicine Lodge 115kV line, near Judson Large, breaker failure at Judson Large	STABLE	STABLE
F083PH	Three phase fault on the Judson Large-Medicine Lodge 115kV line, near Judson Large	STABLE	STABLE
F09SLG	Single phase fault on the Judson Large-Medicine Lodge 115kV line, near Judson Large, breaker failure at Medicine LodgeJudson Large	STABLE	STABLE
F093PH	Single phase fault on the Judson Large-Medicine Lodge 115kV line, near Judson Large, breaker failure at Medicine LodgeJudson Large	STABLE	STABLE

PQ1 – Trip of Previous Queued project #1 (Gray County)

**Table 5. SUMMARY OF FAULT SIMULATION RESULTS**

## **5.0 Conclusion**

The GEN-2005-012 wind farm cannot operate in a stable manner at its requested output of 400MW and no dynamic reactive compensation. No stability concerns exist for the GEN-2005-012 wind farm at the 300MW output with the required capacitors and two (2) 20MVA STATCOM devices. Under these conditions, the transmission system remains stable for all contingencies studied.

The Network Upgrade cost of interconnecting the Customer project is approximately \$905,000. This figure does not address the cost of the Customer substation, the Customer transmission line, the Customer 34.5kV capacitor banks, or the 34.5kV STATCOM devices.

In order for the wind farm to meet the LVRT provisions of FERC Order #661A, the Customer will be required to purchase the Vestes turbines with the AGO-4 option along with the required STATCOM devices.

The costs do not include any costs associated with the deliverability of the energy to final customers. These costs are determined by separate studies if the Customer requests transmission service through Southwest Power Pool's OASIS. It should be noted that the models used for simulation do not contain all SPP transmission service.

## **APPENDIX A.**

### **SELECTED STABILITY PLOTS**

All Plots available upon request

**Page A2** – 2011 SP – Wind Farm Total Power for all Contingencies

**Page A3** - 2007 WP – Wind Farm Total Power for all Contingencies

**Page A4** – 2011 SP - Contingency FLT13PH

**Page A5** – 2011 SWP - Contingency FLT33PH

**Page A6** – 2007 WP - Contingency F05SLG

**Page A7** – 2007WP - Contingency FLT13PH

